

Macsa id[®]
a code you can trust

BiDiLase
The CodeMaster

SO FAST
SO SMART
SO MACSA

The fastest laser coder in the market
for your smart packaging needs

BiDiLase by Macsa
www.bidilase.com



| Nutrition Facts | |
|---|------------|
| Serving size | |
| Amount per serving | |
| Calories | 230 |
| Total Fat | 10g |
| Sodium | 150mg |
| Total Carbohydrate | 45g |
| Dietary Fiber | 10g |
| Sugars | 10g |
| Protein | 10g |
| Vitamin A | 10% |
| Vitamin C | 10% |
| Iron | 10% |
| Calcium | 10% |
| Percent Daily Values are based on a diet of other people's secrets. | |



BiDiLase, THE CODEMASTER THAT OTHERS CANNOT KEEP UP WITH

Macsa offers a complete solution that provides
a unique passport to each package.

BiDiLase is the most innovative and disruptive laser
solution for coding and marking in the world for its:



**SCAN & BE
INFORMED**



(01) 10012345678902
(10) MDL200841432T
(11) 200324
(17) 240324

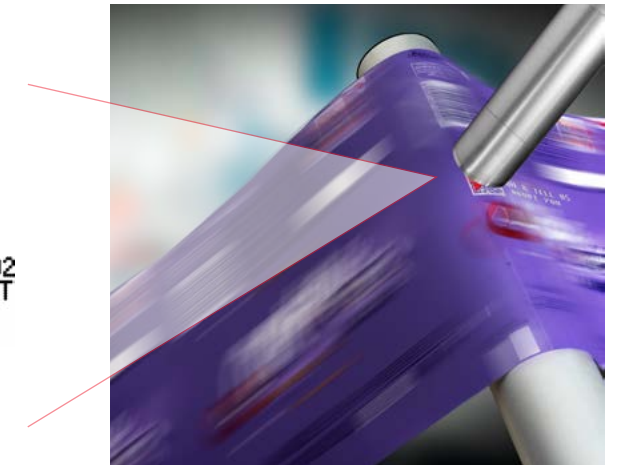

UNRIVALLED SPEED
More than 100 QR codes
per second

It is the fastest laser in the world with a
speed of 1000m/min. It can code faster
than any production line need.



SERIALIZATION
UNIQUE QR codes

Personalise your brand experience with
unique QR codes for each and every one
of your end consumers thanks to Integra
Promo&Serialization software.



PERFECT QUALITY
Class A high definition

High definition and microprecision wi-
thout loss of quality and without the is-
sues related to ink devices.



PREMIUM SCANNABILITY
Flawless readability

Smartphone optimized dot size pro-
vides your users with the optimum 2D
Codes readability.

Supported by

integra
Macsa id



integrapromo&serialization

Software to generate UNIQUE codes at super high speed.

BiDiLase, YOUR PARTNER FOR SMART PACKAGING

BiDiLase provides each product with a unique QR/DM code that enables interaction throughout the complete value chain



Enabling **TRACEABILITY** from production to end customer

Allowing consumer **ENGAGEMENT** through promotions, nutritional information, games, etc.



If that wasn't enough, BiDiLase offers all of the advantages of Macsa laser technology



1. NO CONSUMABLES

A clean technology that does not produce waste.

2. ENVIRONMENTALLY FRIENDLY

It does not generate harmful emissions, which benefits the work environment and the planet.

3. CLEAN

For a cleaner and healthier workspace.

4. ENERGY EFFICIENT

Maximum quality and coding speed with just the right amount of energy.



BiDiLase

The CodeMaster

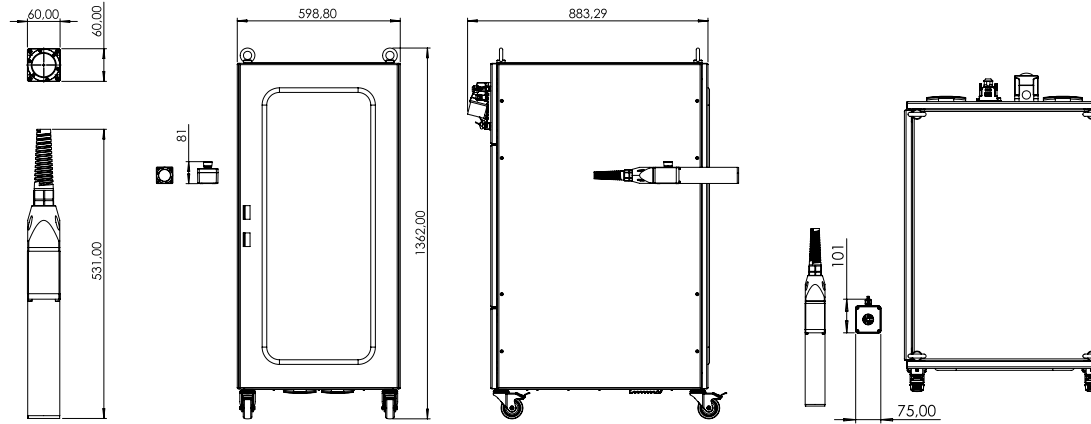

| | |
|---------------------------------|---|
| Voltage | 3 phases + PE 400VAC 4.5KVA |
| Wavelength | 975nm |
| Power | Power up to 240W |
| Print Height | up to 13.6mm |
| Number of dots | up to 35 |
| Cooling | Water |
| Interface | Marca Software v.5.7.8 |
| Software | Scanlinux v.5.5.6 |
| Dimensions (WxDxH) | Rack 600x800x1200 Printhead 60x391x60 Umbilical up to 25m |
| Weight | 250Kg |
| System | Stainless Steel Rack (diode array, power and control modules) Umbilical (fiber optic) Integrable Printhead (optics) |
| Environmental conditions | Temperature 15°C (59°F) – 40°C (104°F) Humidity 10% - 95% |



BiDiLase by Macsa

T. 93 873 87 98
 macsa@macsa.com
 www.macsa.com



Macsa ID Headquarter
 P.I. Pla de Santa Anna
 08272 Sant Fruitós de
 Bages (Barcelona)
 Tel: +34 938 738 798
 Spain

Macsa ID UK
 13d Old Bridge Way
 Shefford
 Bedfordshire
 SG175HQ
 +44 (0)1462 816091
 UK

Macsa ID Portugal
 Rua Eng. Frederico Ulrich n. 2650.
 4470 - 605 Moreira Maia
 Tel: +351 229962204
 Portugal

Macsa ID Malaysia
 E-8-03, The Gamuda Biz Suites
 No.12, Jalan Anggerik Vanilla 31/99,
 Kota Kemuning,
 40460 Shah Alam
 Selangor
 Malaysia

Macsa Coding Technology (shenzhen) Co, Ltd
 East side of 2/F, 7 Building
 Lijincheng Technology Industry Park
 Jihua Road
 Longhua Street, Longhua District
 518100 Shenzhen
 Tel: +86 0755-23611591
 China

Macsa id
 a code you can trust